

## Instructions for Drilling and Assembling Series C Rotary Handle Mechanism for M-Frame Series C Circuit Breakers, Molded Case Switches



### WARNING

**DO NOT ATTEMPT TO INSTALL OR PERFORM MAINTENANCE ON EQUIPMENT WHILE IT IS ENERGIZED. DEATH, SEVERE PERSONAL INJURY, OR SUBSTANTIAL PROPERTY DAMAGE CAN RESULT FROM CONTACT WITH ENERGIZED EQUIPMENT. ALWAYS VERIFY THAT NO VOLTAGE IS PRESENT BEFORE PROCEEDING WITH THE TASK, AND ALWAYS FOLLOW GENERALLY ACCEPTED SAFETY PROCEDURES.**

**THE CUTLER-HAMMER CORPORATION (WESTINGHOUSE PRODUCTS) IS NOT LIABLE FOR THE MISAPPLICATION OR MISINSTALLATION OF ITS PRODUCTS.**

The user is cautioned to observe all recommendations, warnings and cautions relating to the safety of personnel and equipment as well as all general and local health and safety laws, codes and procedures.

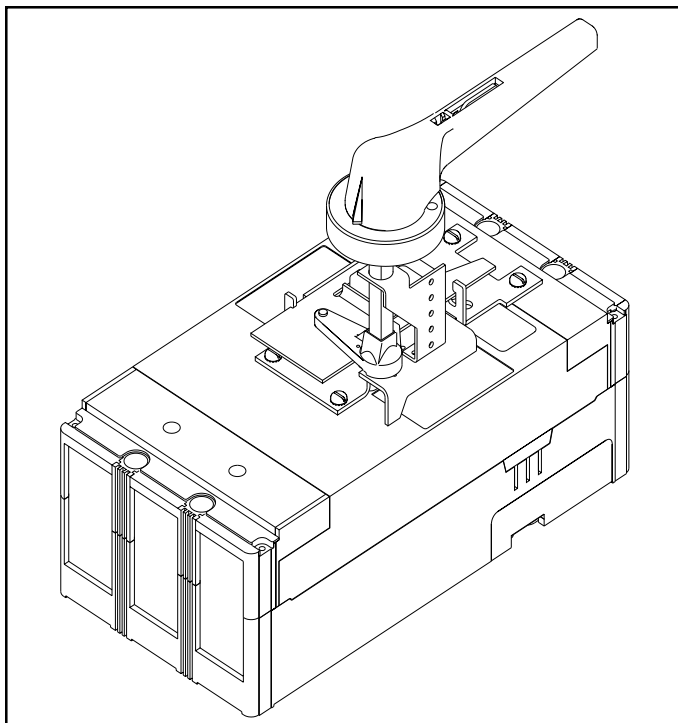

Fig. 1-1 M Rotary Handle Mechanism Assembly

The recommendations and information contained herein are based on Cutler-Hammer's experience and judgment, but should not be considered to be all-inclusive or covering every application of circumstance which may arise. If any questions arise, contact Cutler-Hammer for further information of instructions.

### DESCRIPTION

The Cutler-Hammer general purpose Rotary handle mechanism is suitable for use with NEMA 1, 3R, 12 and 4, 4x fabricated enclosures. For NEMA 4 and 4x enclosures the rotary handle is labeled and gasketed for these applications. It is designed for use with Series C – M-Frame Circuit Breakers and Molded Case Switches up to 800 amps.

Required for a standard application are the operating handle, shaft, and mechanism.

The operating handle has been designed to meet NFPA 79 requirements. It may be mounted in either the horizontal or vertical direction. The handle was ergonomically designed with extra clearance for a "gloved hand" to operate. It may be padlocked in the OFF position utilizing 3 padlocks (.312 Max).

The standard label in the operating handle indicates ON/ Tripped/OFF/Open/Reset. To fulfill international requirements, an alternate handle may be ordered which indicates (I)/Tripped/(O) /Open/Reset.

To meet the various enclosure depths, four variable depth shafts are offered (6", 12", 16", and 24"). Each shaft includes a support brace to ensure proper alignment. In addition, the 16" and 24" extra long shafts include an adjustable support bracket.

The standard mechanism located on the breaker does include means for internally locking the breaker in the "OFF" position with up to 3 padlocks each with a maximum diameter of .312".

As an option, an auxiliary switch is offered so that the control panel builder may electrically indicate the status of the breaker. This accessory would be mounted on the mechanism and comes with 24" pigtail leads.

**INSTALLATION INSTRUCTIONS:**

The installation procedure consists of: drilling and modifying customer enclosure; installing the circuit breaker and operating assembly; assembling the shaft to the operating assembly, and handle assembly to the enclosure cover; testing function of installed handle mechanism. To install the handle mechanism, perform the following steps.

**WARNING**

**WHEN INSTALLING A NEW HANDLE MECHANISM, OR A NEW CIRCUIT BREAKER AND HANDLE MECHANISM IN AN EXISTING ELECTRICAL SYSTEM, MAKE SURE THERE IS NO VOLTAGE PRESENT WHERE WORK IS TO BE PERFORMED. SPECIAL ATTENTION SHOULD BE PAID TO REVERSE FEED APPLICATIONS TO ENSURE NO VOLTAGE IS PRESENT. THE VOLTAGES IN ENERGIZED EQUIPMENT CAN CAUSE DEATH OR SEVERE PERSONAL INJURY.**

**Installation of Circuit Breaker and Operating Assembly**

1. Determine position for circuit breaker in enclosure. Drill and/or tap circuit breaker mounting holes in enclosure mounting surface as shown in Fig. 2-1.
2. Turn circuit breaker to "OFF" position.
3. Mount circuit breaker to enclosure using the four (4) 5/16-18x1.25" long screws in the hardware kit. Insert screws and lockwashers into load and line end circuit breaker mounting holes and tighten securely. (Fig. 2-2.)
4. Mount mechanism onto circuit breaker, ensuring slide plate is engaged with the circuit breaker handle. Remove the (2) breaker cover screws and (2) load cover screws as shown in Fig. 2-2 and discard. Insert the (4) screws (.190-32 x 1.75) enclosed, along with lockwashers from the hardware kit, through the mounting holes of the mechanism and into the empty cover screw holes of the circuit breaker, as shown on Fig. 2-2.

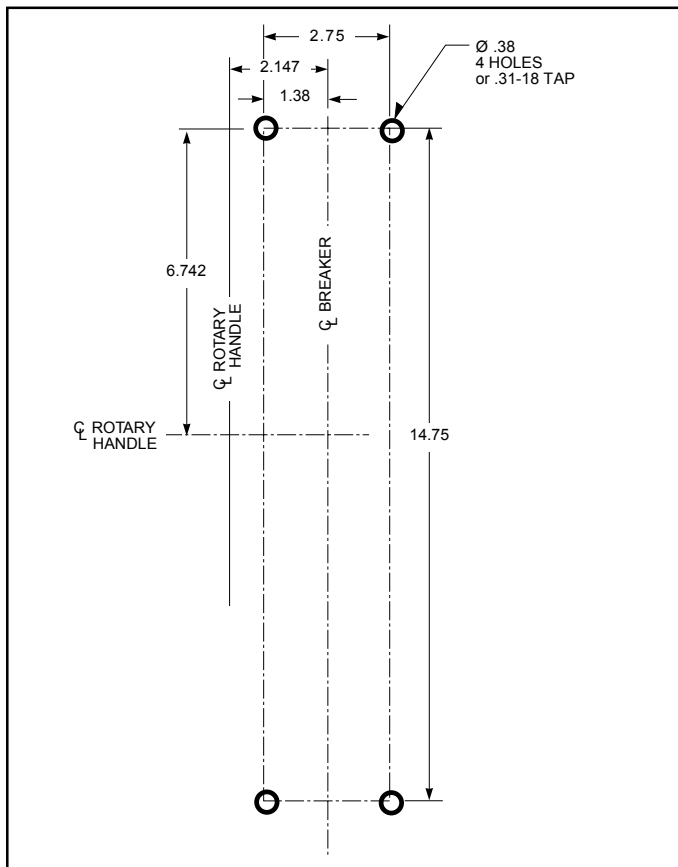

Fig. 2-1 Drill & Tapping Plan for M-Frame Breaker

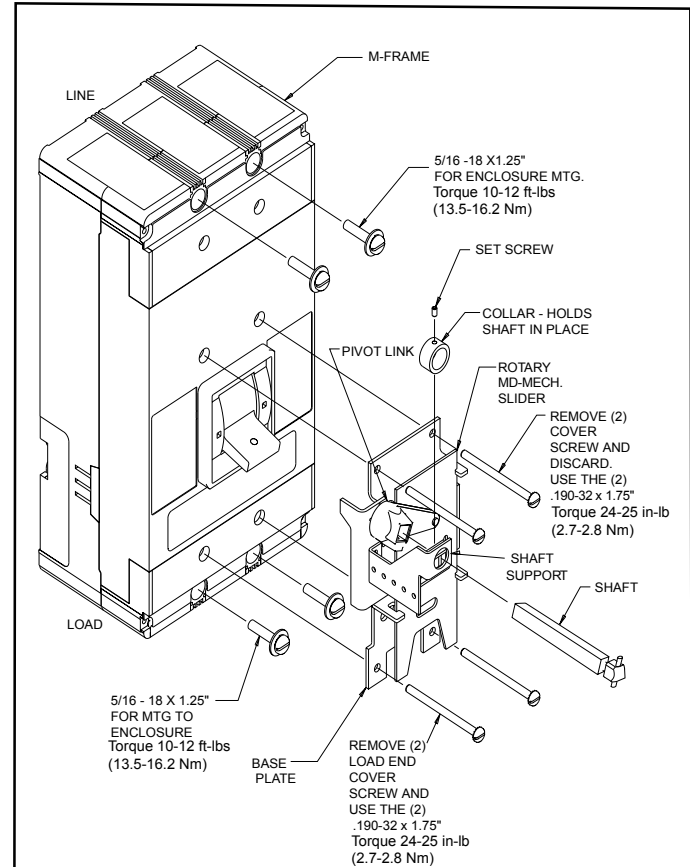

Fig. 2-2 M-Frame Breaker/Mechanism Assembly

### Installation of Shaft to Operating Assembly

1. Measure panel depth "D" to determine shaft length by subtracting 4.50" from this dimension.

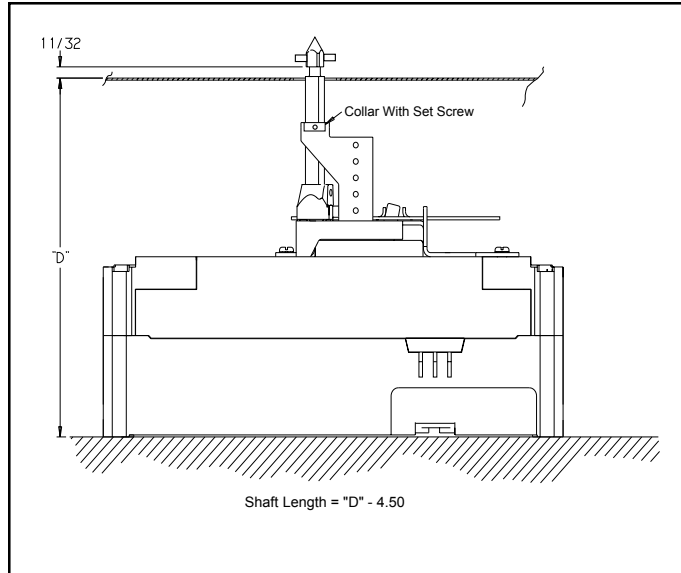

Fig. 3-1 Cutting Shaft to Length and Collar to Shaft

2. Mark shaft, measuring length beginning at the pointed end and cut to correct length. (Fig. 3-1)
3. If adjustable support extension is being used (designed for 16" and 24" shaft lengths), install loosely at this time. Remove screws from extension and use to attach to shaft support bracket.
4. Place square end of shaft into square opening of die cast pivot link on the operating mechanism to the circuit breaker. Ensure pin is in shaft correctly oriented with respect to anticipated handle position (vertical or horizontal handle placement, see Fig. 3-2).
5. Take set screw and shaft collar from hardware kit and insert set screw into shaft collar. Place square end of shaft through shaft support bracket then through shaft collar and into square opening of die cast pivot link on the operating mechanism attached to the circuit breaker, as shown on Fig. 2-2. Position shaft collar lightly against the underside of the shaft support collar and torque set screw between 28-30 in-lbs.
6. For vertical or horizontal handle mounting orientation, see Fig. 3-3.
7. If adjustable support extension is being used, tighten securely at this time.

Distance from Hinge	Correction	
	Flat Hinge	Offset Hinge
4	3/16"	9/16"
5	5/32"	7/16"
6	1/8"	11/32"
7	3/32"	9/32"
8	3/32"	1/4"
9	3/32"	7/32"
10	1/16"	3/16"
11	1/16"	3/16"
12	1/16"	5/32"

Table 4.1 Correction Factor Table

### Installation of Handle Assembly onto Enclosure Cover

1. To determine where to drill the enclosure door cover, close the cover with moderate force in order to cause the point of the shaft to scratch/mark the paint on the inside of the door.

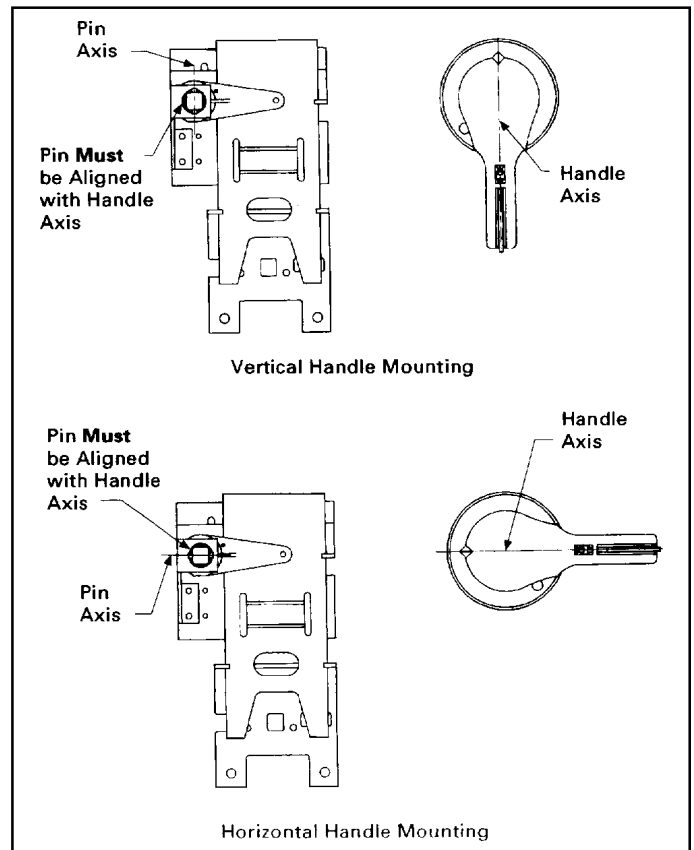

Fig. 3-2 Handle Orientation

2. Prior to drilling the 1.50" diameter hole in the cover door, use correction factor per table 4.1. Correction should be made from mark on door (step 1) towards hinge. Drill 1.50" Dia. Hole.
3. After the hole is drilled, close enclosure cover allowing the shaft to stick through the opening. Check this dimension per Figure 3-1.
4. Close enclosure door. Place gasket/template supplied in hardware kit. Place the template over the shaft ensuring the text/wording is facing outward. With the use of your fingers remove any play by rotating the shaft in a clockwise motion. Align the template cutout with the shaft profile and mark the handle mounting holes. Drill (4) .281" (7.0mm) diameter holes.
5. Carefully remove the inner portion of the gasket/template keeping the outer gasket ring and place it between the handle assembly and door. If this installation is a NEMA 4 or 4X use the neoprene gasket supplied with the hardware kit. Loosely drive the four 1/4-20 x 0.5 screws through both the door and gasket from the inside of the enclosure door cover and into the handle assembly. Tighten evenly to 43-44 in-lbs (4.8-5.0 Nm). For International handle styles, the handle Mounting hardware is similar to the M6 x 1 x 12 mm screw if misplaced.
6. With power isolated from the circuit breaker, test function of installed handle mechanism in the following manner:
  - a. Close enclosure door. Switch handle mechanism to ON.
  - b. Check the handle mechanism switches circuit breaker to ON position and that enclosure door cannot be opened.
  - c. Switch handle mechanism to OFF Position.
  - d. Check that handle mechanism switches circuit breaker to OFF position and that enclosure door cannot be opened.
  - e. Turn handle to OPEN position and ensure door opens.
  - f. Close enclosure door. Switch handle mechanism/circuit breaker to ON.
  - g. Turn interlock defeater counterclockwise with a flat-blade screwdriver.
  - h. Open enclosure door.
  - i. Press Push-to-Trip Button in the circuit breaker trip unit with a small flat-blade screwdriver to trip circuit breaker.
  - j. Align handle assembly with shaft and close enclosure door.
  - k. Switch handle mechanism to (RESET) position. Check to ensure breaker resets.
7. Downloadable CAD files are available on the Eaton website. Visit [www.eaton.com](http://www.eaton.com) in the electrical market section. Search CAD download area for your specific product or simply search for 1498D75.

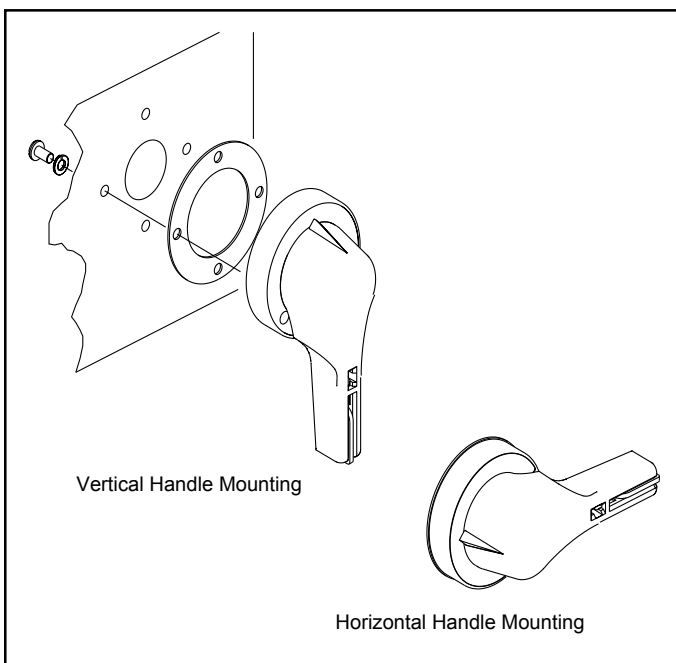

Fig. 3-3 New Handle on Door



**NOTES**

**NOTES**

Eaton Corporation  
Cutler-Hammer business unit  
1000 Cherrington Parkway  
Moon Township, PA 15108-4312  
USA  
tel: 1-800-525-2000  
[www.cutler-hammer.com](http://www.cutler-hammer.com)

© 2001 Eaton Corporation  
All Rights Reserved  
Printed in U.S.A./TCQ  
Style No. 6608C10H05  
Effective August 2009